

INSTALLATION INSTRUCTIONS
DESCRIPTION: Heated Seat Cover
PART NUMBER: 2PG-F470B-T0-00
MODEL: 2015 Viking VI



⚠ WARNING

Please read and understand these instructions completely before installation to avoid possible injury, or damage to the accessory or vehicle.

WARRANTY INFORMATION:

Genuine Yamaha accessories are covered by a one-year warranty against defects in material or workmanship. Labor for replacement of defective components is not covered. See your Yamaha dealer for a copy of the warranty statement.

DEALER OR INSTALLER:

These instructions contain important information for future reference and *must* be given to the customer.

PARTS LIST:

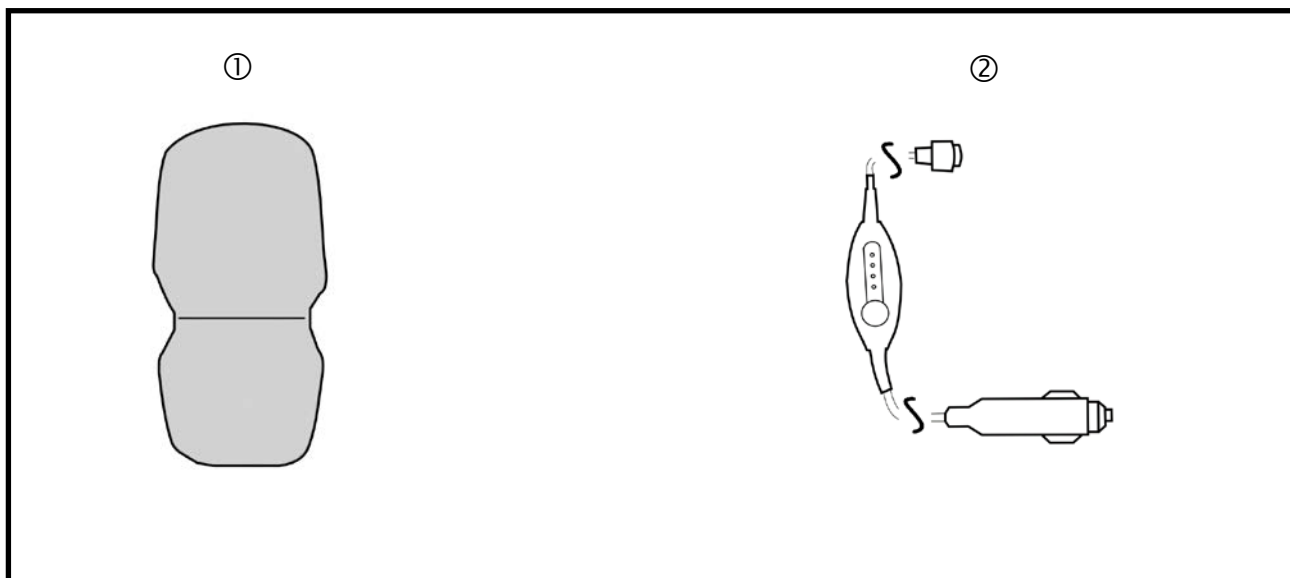

No.	Part Number	Description	Qty
--	2PG-F470B-T0-00	Heated Seat Cover Kit (cover for 1 seat)	--
①	*	Seat Cover	1
②	*	Controller	1

* Part supplied with kit only and not available separately.

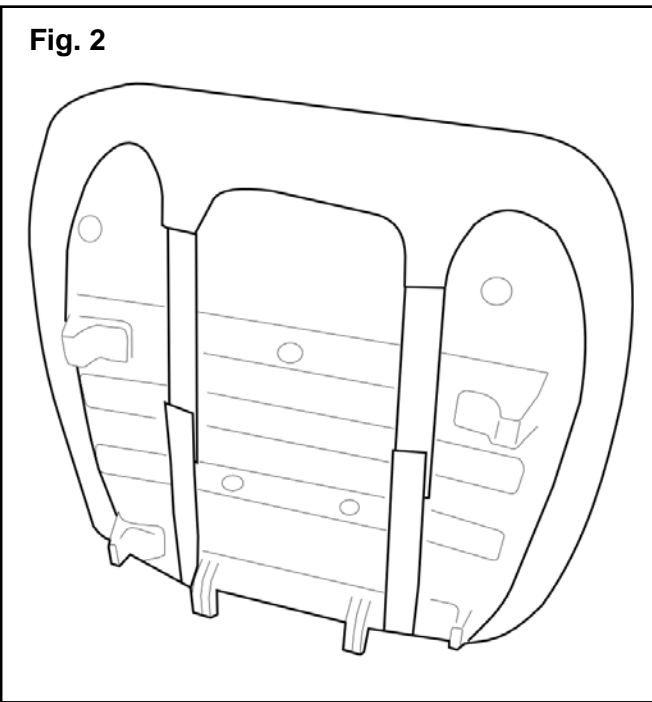
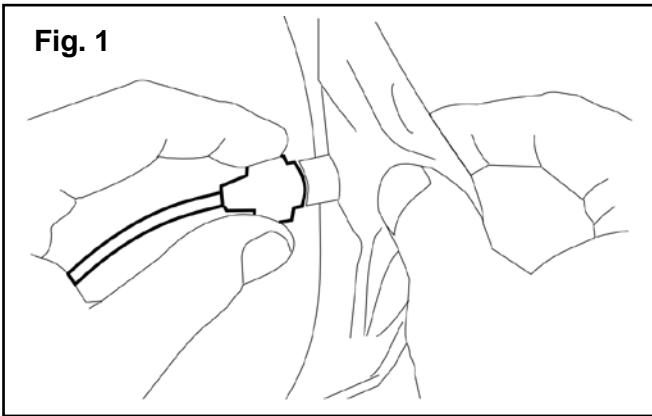

PREPARATION:

1. Place vehicle on a secure and level surface.
2. Set the parking brake.
3. Clean all mounting surfaces before beginning installation.

INSTALLATION:

1. Connect controller to socket on underside of cover (Fig. 1). Lift up seat base and install cover onto seat as shown in Fig. 2.
2. Install seat cover over seat back.
3. Route controller wire to DC outlet on vehicle.

⚠ WARNING

Route and secure wiring away from sharp edges and moving parts, so that it does not interfere with passenger movement or operation of the vehicle. Never adjust heat controller settings while operating the vehicle.

NOTICE:

This accessory includes a feature that automatically powers off the heated cover after fifteen minutes of operation. Therefore, it is normal for the cover to turn off after fifteen minutes of use.

MAINTENANCE:

Periodically check the connection between the controller and socket. Check that seat cover is positioned correctly on seat and straps are properly secured underneath the seat base.

CARE AND CLEANING:

Hand wash using a mild soap and water solution. Hang to dry.

CUSTOMER SERVICE:

For further information see your Yamaha dealer.

ESTIMATED TIME TO INSTALL: 0.2 HRS